



Cast Iron Top Kit Code 717126

Laminated Top Kit Code 719241

Original Instructions

Compact Router Table

Hole assembly instructions including the UJK table tops, fence assembly, table inserts and other accessories



INDEX OF CONTENTS

• Introduction	03
• What's Included	04-05-06-07
• Optional Accessories	08-09-10-11
• Kit Specification	12
• General Instructions for 230V Machines	12
• General Safety Instructions	13
• Assembly	14-15-16-17-18-19-20-21
• Illustration & Parts Description	22-23
• Mounting the Router to the Universal Base Plate	24-25
• Mounting the Router to the 10mm Table Inserts	26-27-28
• General Guide to Router Cutters	29-30
• Exploded Diagram/Parts List	31-32-33-34-35

Axminster Tool Centre Ltd
Axminster Devon
EX13 5PH UK
axminstertools.com

declares that the machinery described-

Type	Router Table
Model	UJK

Signed



Andrew Parkhouse
Operations Director

Declaration of Conformity

EC DECLARATION OF CONFORMITY
MACHINERY DIRECTIVE, UJK ROUTER TABLE,
Axminster Tools and Machinery Ltd
declares that the attachment described
under Technical Data is in compliance with:

2006/42/EC



The symbols below advise the correct safety procedures when using this machine.



Fully read manual
and safety instructions
before use



Ear protection
should be worn

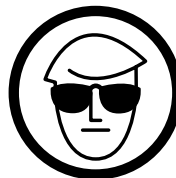

Eye protection
should be worn



Dust mask
should be worn

The UJK Compact Leg Stand

With splayed legs is of sturdy construction, very stable and of a size that offers portability around the workshop or on site. Provision is made for storage of the supplied mitre fence assembly. Measuring 370mm high, with a footprint of 580 x 390mm, this leg stand is such a useful size and could also be used for mounting many other small machines.



The UJK Compact Cast Iron Router Table

Top is one of a range of options that you can choose from when making up your UJK router table. Simply add the leg stand, fence and required insert and you will have a very sturdy versatile unit capable of many routing operations. The benefits of using cast iron for the manufacture of machine tables are well known especially where vibration damping and stability are paramount. The quality of the surface grinding on this 686 x 406 x 40mm top is superb, offering little resistance when passing stock across the table during use. A standard 19mm wide slot is incorporated for the use of a mitre fence attachment and a T-slot is also present for jigs and accessories. The top is threaded to accept the UJK compact leg stand, fence assembly and optional dust collection box. The 230 x 306mm central aperture will accept the router elevator and other available UJK insert options.



The UJK Compact Laminated Router Table

Top is high grade birch ply with a hard wearing, low friction, phenolic laminated surface. The ply core ensures the top will remain flat throughout its working life, while the laminated top ensures workpieces glide smoothly. An extruded aluminium track inset into the tabletop includes a standard 19mm track for the use of a mitre fence and a T-track slot for other jigs and accessories. The 230 x 306mm central aperture will accept any of the UJK router table inserts as well as the UJK router elevator. The top measures 600 x 400 and is pre-drilled to fit the UJK Compact router table leg stand, fence assembly or optional dust collection box.

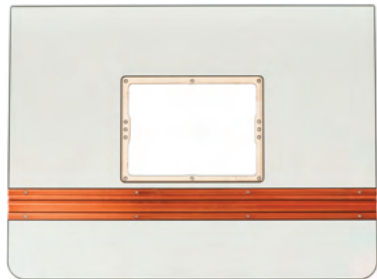

The UJK Compact Router Table Fence is a beautifully made, single piece aluminium section supplied with a transparent 63mm dust port for efficient extraction from above the table. Provision is made for the fitting of guards and accessories with a T-slot at both the top and front of the fence. An adjustable transparent guard is included for your safety. Adjustable scales are provided for attachment at either side of the table and the fence is attached to these locking into place in the required position. A scale is also provided along the top of the fence with the zero position at the centre. Adjustable infeed and outfeed fences attach to either side of the aluminium section and the central aperture can be opened and closed according to the diameter of the cutter in use. Fence measures 789 x 90mm.



WHAT'S INCLUDED

UJK Router Table Stand

Quantity	Item	Part	Code
502533			
Bag 1 Containing:			
1 No	Mitre Fence Bracket Holder with two Phillips screws and washers	1	
Bag 2 Containing:			
1 No	Tool Bracket (with two pre-drilled holes)	2	
4 No	Rubber Feet	3	
4 No	Phillips Screws (M6x20mm)	4	
2 No	Phillips Screws (M4x20mm)	5	
34 No	Coach Bolts (M6x12mm)	6	
38 No	Flat Washers (M6)	7	
38 No	Nuts (M6)	8	
2 No	Nuts (M4)	9	
1 No	Mitre Fence	10	
1 No	Mitre Fence Extension (with two Butterfly nuts and washers)	11	



UJK Router Table Stand

Quantity	Item	Part	Code
			502533
4 No	Leg Supports Brackets	A	
2 No	Front and Back Upper Panels	B	
1 No	Front Lower Panel	C	
2 No	Side Lower Panels	D	
2 No	Side Upper Panels	E	
1 No	Side Centre Panel	F	
1 No	Rear Extractor Panels	G	

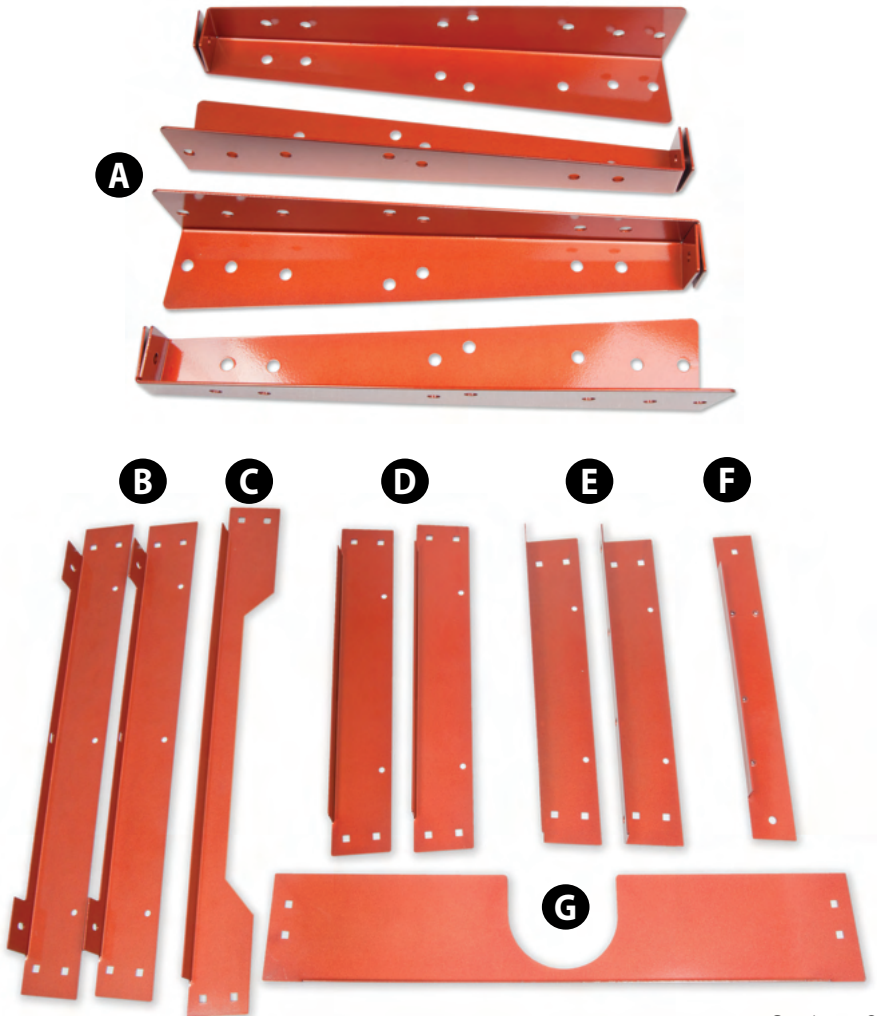

WHAT'S INCLUDED

UJK Router Table Tops

Quantity	Item	Part	Code
1 No	UJK Compact Cast Iron router table top	A	502532
1 No	UJK Compact Laminated router table top	B	102544

Bag Containing	Code 502532
10 No	Countersink Phillips Screws (M6x20mm)
10 No	M6 Nuts
10 No	Hex Bolts (M6x12mm)
10 No	M6 Washers
10 No	Spring Washers

Bag Containing	Code 102544
10 No	Countersink Phillips Wood Screws
6 No	Phillips Head Wood Screws

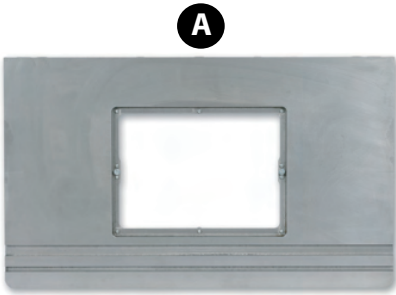

UJK Pro Cast Iron Table Top

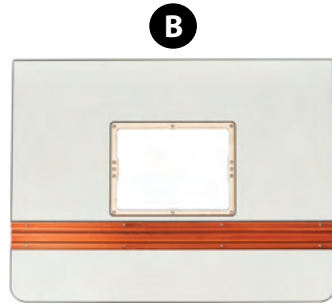

UJK Laminated Table Top

UJK Fence Assembly

Quantity	Item	Part	Code
1 No	Fence	H	508272
1 No	Extraction Moulding	I	
1 No	Dust Shield	J	
2 No	Fence Fixing Brackets with Scale	K	
2 No	Fence Fixing Brackets	L	
2 No	Adjustable Wood Faces	M	
1 No	Bag Containing	N	
2 No	Locking Handle Knob (5/16")	a	
8 No	M8 Locking Knobs	b	
2 No	Fence Spacers	c	
8 No	'T' Bolts (M8x43mm)	d	
6 No	Hex Screws (M6x12mm)	e	
6 No	Hex Bolts (1/4") (with flat & spring washers)	f	
2 No	Lock Hex Nuts (5/16")	g	
6 No	Square Nuts (1/4")	h	
10 No	M8 Flat Washers	i	
6 No	M6 Flat Washers	j	

WHAT'S INCLUDED

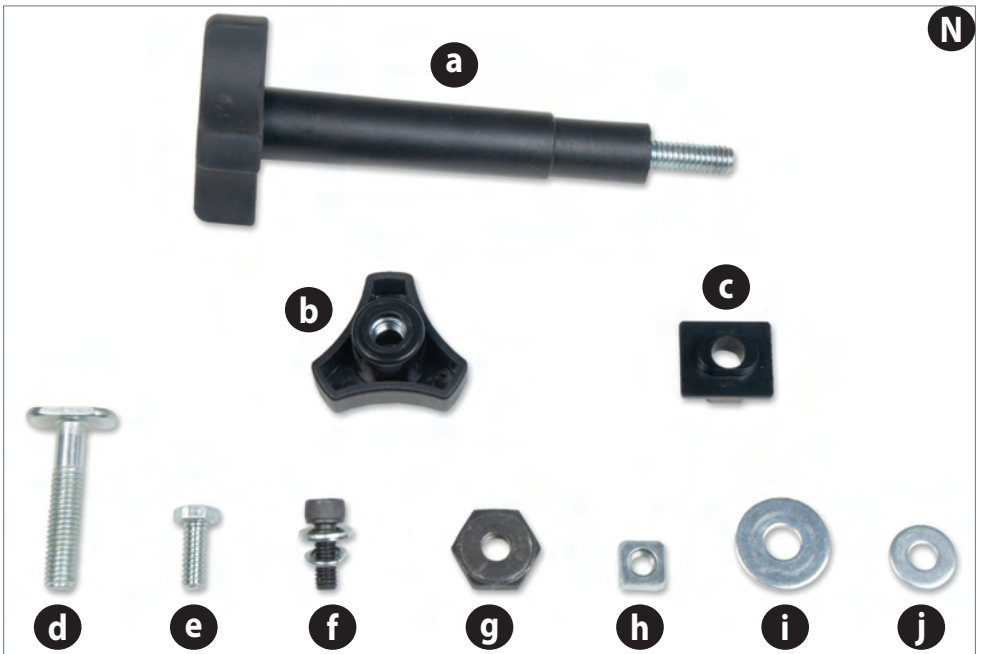
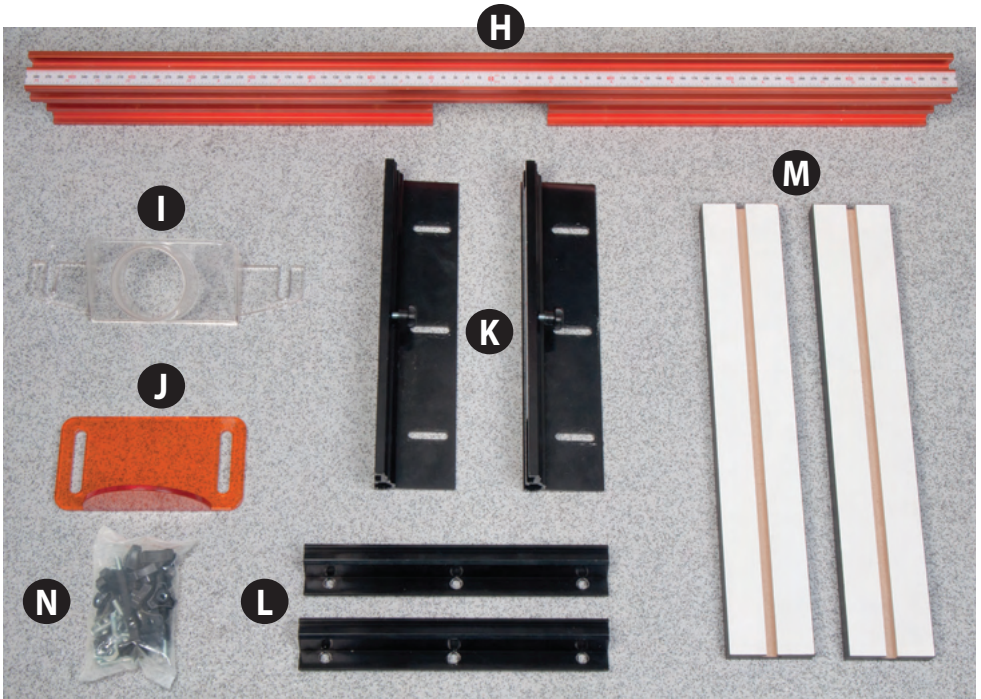

OPTIONAL ACCESSORIES

1) UJK QuickStop

(Code 502569)

- A hinged stop to fit the UJK router tables.
- An excellent device for stopped chamfers or rebates.
- Attaches to the top of the router table fence.
- Simply flips up out of the way when not required.

2) UJK 10mm Aluminium Router Table Insert c/w Universal Base

(Code 502748)

UJK 10mm Aluminium Table Insert

(Code 105932)

- Threaded lead-in pin.
- To fit 230 x 306mm aperture.
- Twist lock insert ring supplied with wrench.

3) Router Table Inserts

- A range of central inserts for the
- UJK router elevator
- Also suitable for UJK aluminium and phenolic router table insert plates.
- Sizes include 12.6mm, 38mm, 63.4mm plus a guide bush adaptor.
- Blank insert available for making your own hole size.
- Available as a set of four or individually.

(Code 502565) **12.6mm**

(Code 502566) **38mm**

(Code 502567) **63.4mm**

(Code 951187) **Blank Insert**

(Code 502525) **Guide Bush Adaptor**

4) Vertical Feather Boards

(Code 502751)

- Gives downward pressure against workpiece.
- Excellent for safer routing.

5) Horizontal Feather Boards

(Code 502750)

- Holds workpiece against fence.
- Excellent for safer routing.
- Use as singles or stacked for more support.

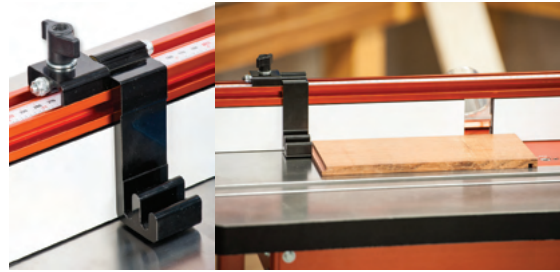

502748



105932



502751



502750



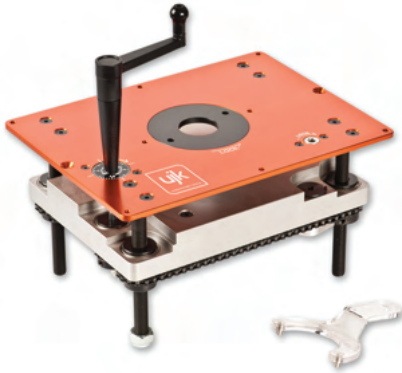

6) UJK Router Elevator

(Code 502701)

The UJK router elevator is a logical solution for fast, accurate production on many router table installations. This compact design was developed by us to fit straight into our own router tables and most table set-ups can accommodate this size of insert (305 x 229 x 6mm). The unit can be made to fit flush into the tabletop by the provision of levelling screws at each corner of the table insert. Height adjustment is carried out by inserting a handle through a measurement dial set into the machine table. Each rotation of the handle raises or lowers the cutter by exactly 2mm and the integral scale is graduated into increments enabling very accurate adjustments to be carried out.



7) UJK Dust Extraction Box

(Code 502538)

- Dust collection device.
- Efficient extraction from above and below the table.
- Access door with magnetic catch.
- 63mm extraction hose included.
- 100mm outlet.



Dust extraction from a router table can be difficult and for it to work effectively it needs to extract from both above and below the table. Designed to fit the UJK Pro and Compact router tables this device fits below the table top enclosing the router. It could also be fitted to other custom made tables of your own design. The 100mm diameter outlet on the back also incorporates a 62mm inlet and hose which enables extraction from both above and below the table simultaneously. An access door is provided on the front with a magnetic closure enabling access to your router for adjustments if required. Measures 330 x 260 x 350mm high with an access aperture of 225 x 170mm.



8) UJK Off Set Bars for Router Tables

(Code 103561)

A pair, these H-section extrusions fit behind the outfeed fence of the UJK router table fence. Once in position they give you an exact 1mm offset between the infeed and outfeed fences. Their clever design means you can rotate each extrusion by 180° and reinsert them in position to achieve an exact 2mm offset.



OPTIONAL ACCESSORIES

9) UJK Digital Height Gauge

(Code 103655)

The UJK Digital Height Gauge is an indispensable measuring tool for the accurate setting of cutting depths, in particular router cutters and saw blades.

The body is cast iron, with machined feet that form a reference surface. It is stable and can stand upright without additional support. It is equally accurate both vertically and horizontally. The horseshoe shaped body measures 54mm between the legs with an internal height of 80mm. The main feature is its highly accurate digital scale unit, with an LCD screen offering a read-out in either metric or imperial. The display has a resolution of 0.01mm or 0.001 inches.

The digital read-out tells you precisely how deep your saw blade or router cutter is going to cut. With a measuring speed of 1.5 milliseconds, it is somewhat faster than making a guess with a ruler. You can zero the digital read-out at any point, allowing relative adjustment. It is particularly handy to hold the bar in contact with the blade or cutter and gradually increase the cutter height until the display reaches the desired depth. Used horizontally, you can measure or adjust a router table fence relative to the cutter. The UJK Digital Height Gauge will also measure a mortice to a depth of 99mm.

10) UJK Precision Mitre Gauge Fence & Flip Stop

(Code 104579)

This mitre gauge system is made from 5mm steel plate and features positive stops at 0°, 22.5°, 30°, 45°, 60°, 67.5° and 90°. Simple to adjust with a spring loaded plunger stop and able to be set at any other angle between 0-90° as required.

The other main feature is the anodised alloy fence, fitted with an adjustable flip-over length stop. This fence can be slid along the gauge body by releasing two thumb screws. The 320mm bar can be fitted to a standard 3/4" x 3/8" (19 x 9.5mm) table slot; the locking washer can be removed if required.

This mitre gauge will improve accuracy when cross or mitre cutting on many machines or router tables.

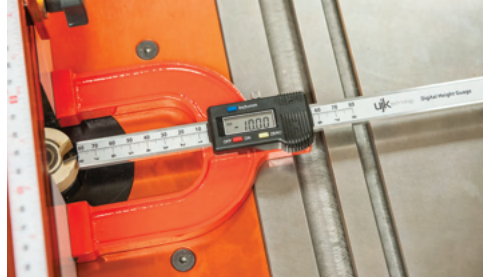

11) UJK Professional Coping Sled

(Code 102946)

When profiling the end grain of a narrow workpiece on the router table, you need a way of holding the workpiece. This is particularly relevant if your workpiece is narrower than the gap in your router fence. The UJK Coping Sled holds the key to working safely, securely and achieving accurate results.

Developed and extensively tested by UJK, this Coping Sled will transform the way you make end grain cuts for rail and stile doors, tenons and many other joints. If you are intending to make cabinet doors on your router table, the Coping Sled is invaluable. It is by far the best way to secure your workpiece, offering perfect results with a high degree of safety. The Coping Sled takes the stress out of the process. It ensures your workpiece is square to the table's mitre slot and that it guides smoothly across the router bit.

The Coping Sled secures your workpiece both horizontally and vertically. A slotted top plate holds the work firmly against the sled's rear fence. This plate prevents kickback and easily adjusts for material up to 135mm wide. Two vertical clamps prevent the workpiece lifting during the cut. The position of the foremost clamp, close to the point of cut, significantly reduces vibration. The maximum workpiece thickness is 40mm.

To prevent tear-out at the end of the cut, the Coping Sled has a 45mm wide x 22mm deep nylon fence. Unlike aluminium, nylon will not damage your router cutter. You can use the fence as a spelcher if you wish or use an off-cut to prevent tear-out. The fence includes a sliding flip-stop for repeat cuts. A T-slot cutter is available should you wish to make a replacement or custom wooden fence.

On the underside of the 10mm thick, low-friction base-board is a 19 x 9.5mm (3/4" x 3/8") mitre slot bar. It will fit both plain and T-slot mitre slots. Two grub screws, 150mm apart, allow adjustment for zero play in the slot. The bar has a choice of five positions to accommodate a wide variety of router tables.

Two large rubberised handles provide a firm safe grip for complete control. The design allows you to position the handles directly over the work. The sled's handles make sure both your hands remain a safe distance from the router bit. A clear, full width Plexiglas shield acts as a chip deflector.

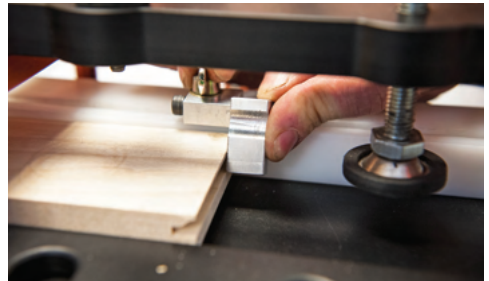

KIT SPECIFICATION

UJK Compact Router Table with Cast Iron Table Top

Code	717126
Rating	Trade
Table Size	686 x 406 x 40 mm
Fence Size	789 x 90 mm
Dust Extraction Outlet	62 mm

UJK Compact Router Table with Laminated Table Top

Code	719241
Rating	Trade
Table Size	600 x 400 x 22 mm
Fence Size	789 x 90 mm
Dust Extraction Outlet	62 mm

GENERAL INSTRUCTIONS FOR 230V MACHINES

Good Working Practices/Safety

The following suggestions will enable you to observe good working practices, keep yourself and fellow workers safe and maintain your tools and equipment in good working order.



WARNING! KEEP TOOLS AND EQUIPMENT OUT OF THE REACH OF YOUNG CHILDREN

General Advice

If you are totally unfamiliar with the use of a power router, please seek some basic tuition and advice from an informed, qualified source. An amateur woodworker or hobbyist just starting out is advised to undertake a short course on the use of woodworking machines run by a professional woodworker. These are often offered by your local authority as evening classes.

Mains Powered Tools/ Primary Precautions

These tools are supplied with a moulded 13 Amp. plug and 3 core power cable. Before using the tool inspect the cable and the plug to make sure that neither are damaged. If any damage is visible have the tool inspected/repared by a suitably qualified person. If it is necessary to replace the plug, it is preferable to use an 'unbreakable' type that will resist damage on site. Only use a 13 Amp plug, make sure the cable clamp is tightened securely and check that a 13 Amp fuse is fitted. It is also recommended that a switched power outlet is used. If extension leads are to be used, carry out the same safety checks on them, and ensure that they are correctly rated to safely supply the current that is required for your machine.

General Safety Instructions

- Carefully study and observe the safety instructions issued with the router being used in the table.
- In addition, the following precautions, specific to the use of router tables, should be adhered to.
 - Ensure that the router is securely fixed to the router table, both when first commissioned and periodically thereafter.
 - Fix the router table to a firm base such as a workbench or a heavy table. If the table is attached to a false base this in turn should be firmly fixed to a workbench or other solid surface.
 - Always wear appropriate safety equipment such as safety goggles or face shield, dust mask and ear defenders. Ties, loose clothing and jewellery are all potential safety hazards and should be avoided.
 - The router table is intended for cutting timber and plastics only, do not use it with other materials. Long lengths of timber will need to be supported on both the in-feed and out-feed sides of the table.
 - Timber should be fed into the cutter from the right hand side of the table, as indicated on the safety label attached to the fence. A push block or custom made work holder should be used when cutting small pieces.
 - Router cutters should be installed correctly in the router with the recommended minimum length of shaft engaged in the collet and the collet tightened to the correct degree.
 - When making any adjustments to the router, such as changing the cutter, ensure that the router is switched off and the power cable is removed from the power supply before proceeding.

GENERAL SAFETY INSTRUCTIONS

- 1.** Make sure that the operator has been properly trained and has read and understands the Owner's Manual before operating any machinery.
- 2.** Be sure to read, understand, and follow all instructions, warnings, and safety guidelines supplied with your router.
- 3.** Keep the work area well lit, clean, and free of debris.
- 4. STAY ALERT!** Give your work your undivided attention. Even a momentary distraction can lead to serious injury.
- 5.** Do not wear loose clothing, gloves, bracelets, neck-laces, or other protection devices. Wear protective hair covering to contain long hair and wear nonslip footwear.
- 6.** Keep hands and other body parts well away from bits or cutting tools. When working close to the cutting tool, always use a feather board or push-stick to hold or guide the workpiece. Do not clear chips and sawdust away with hands; use a brush.
- 7.** Fine particulate dust is a carcinogen that can be hazardous to health. Always work in a well ventilated area and whenever possible use a dust collector to minimize health hazards.
- 8.** Be sure the router is running up to speed before feeding the workpiece.
- 9.** Use a suitable support if stock does not have a flat surface.
- 10.** Keep children and visitors at a safe distance when the router is in operation - do not permit them to operate the router and/or table.
- 11.** Childproof and taper proof your shop and all machinery with locks, mater electrical switches and switch keys, to prevent unauthorised or unsupervised use.
- 12.** Secure the table to a work surface and never stand or lean on it. Serious injury can occur if the table is tipped or if unintentional contact is made with the spinning router bit.
- 13.** Keep all guards and safety devices in place and in good working order. If a guard must be removed for maintenance or cleaning make sure it is properly reinstalled before using the machine again.
- 14.** Hold the workpiece firmly against the table and use suitable support if the workpiece does not have a flat surface.
- 15.** Feed the stock into the bit against the rotation direction of the bit. Never run the stock between the fence and the bit.
- 16.** Do not operate with a damaged cutter in the router.
- 17.** Always disconnect the router from the power source before changing accessories or before performing any maintenance and adjustments or if the machine will be left unattended.
- 18.** Be sure that all adjustment tools, wrenches, or other clutter are removed from the table surface and safely stored before routing.
- 19.** Make sure the router's switch is in the "OFF" position before plugging in to a power source.
- 20.** Avoid working from awkward or off-balance positions. Do not overreach and always keep both feet firmly on the floor.
- 21.** Never leave the router unattended while running or with the power "ON".
- 22.** Do not use this router table for any purposes other than its intended use. If used for other purposes, UJK disclaims any real or implied warranty and holds itself harmless for any injury which may result from such use.

ASSEMBLY

UJK Router Table Stand Assembly

Step 1 Locate the bag containing the coach bolts (M6x12mm) (6), M6 flat washers and nuts (7-8), leg support brackets (A) and side upper/lower panels (D-E). Offer up the pre-drilled holes in the leg supports with the holes in the upper/lower panels as shown in fig 1 and secure using the M6 nuts bolts washers. DO NOT OVERTIGHTEN. Repeat for the remaining legs (A) and panels (D-E).

Fig 01

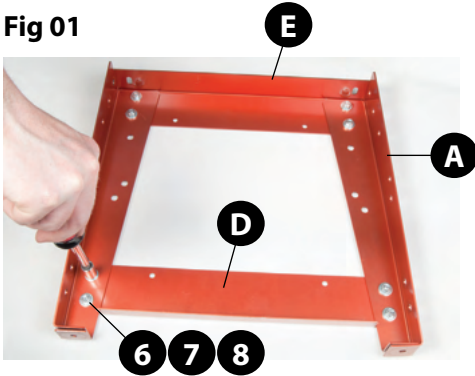

Step 2 Locate the side centre panel (F) and one of the stand sides, offer up the holes in the centre panel with holes in the centre of the leg supports (A) and secure with M6 fixings (6-7-8), see fig 2



NOTE LEAVE FIXING HOLE (A) CLEAR TO MOUNT THE TOOL BRACKET (2) LATER IN THE ASSEMBLY.

Fig 02

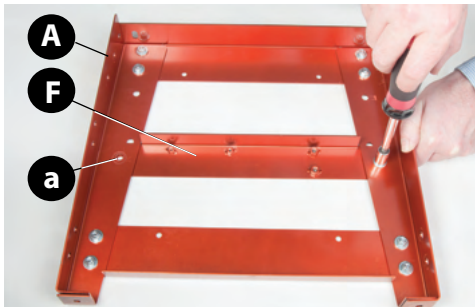

Step 3 Find the rear extractor panel (G) and front lower panel (C). Lightly tighten both panels to the stand side as show in fig 3, using the M6 fixings. Attach the remaining stand side to the other end, see fig 4.

Fig 03

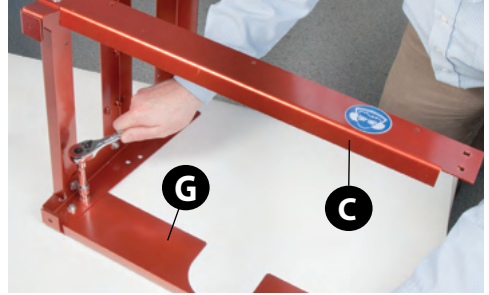

Please note: Part 'C' 'Front Lower Panel' has been recently modified, images show the previous version

Fig 04

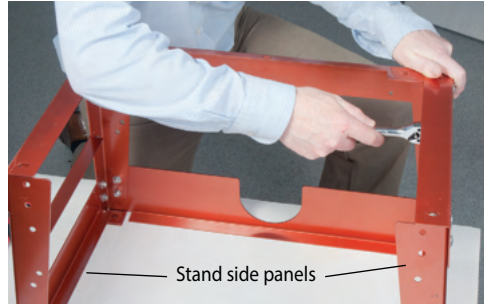
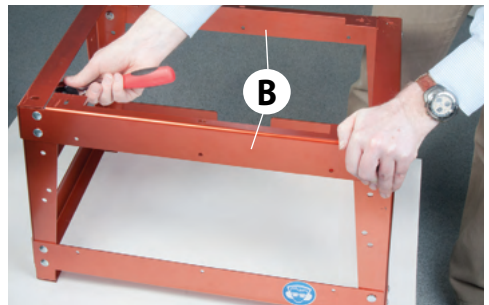

Fig 05



Step 4 Locate the front and back upper panels (B) and attach it to the frame work as shown in fig 5, then go round and tighten all the fixing.

Step 5 Locate the four rubber feet (3), (M6x20mm) Phillips screws (4), flat washers (7) and M6 nuts (8), see fig 6. Turn the stand over, place a rubber foot on top of the leg support bracket (A) and line up the pre-drilled holes. Place a flat washer (7) over the Phillips screw (4) and insert the screw into the foot's recess, secure in place with the nut (8), see fig 6-7. Repeat the process for the remaining feet, see fig 8.

Fig 06-07

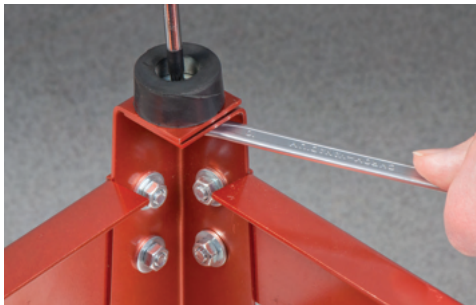
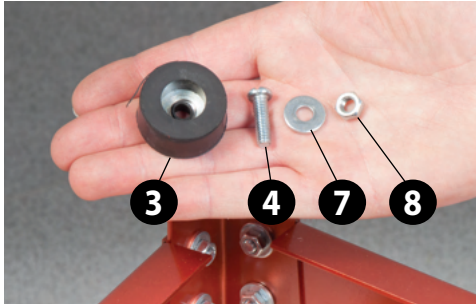
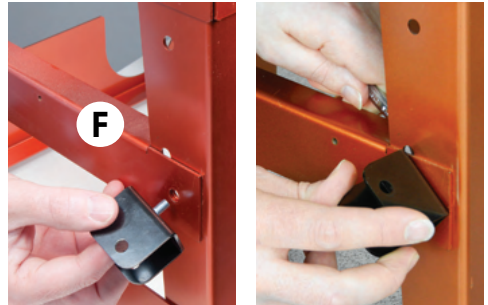
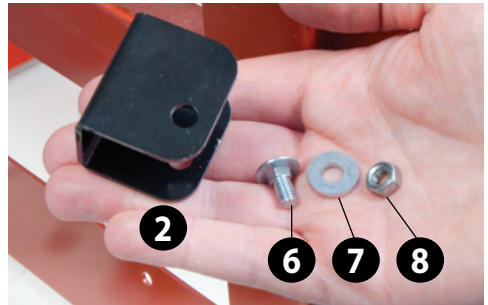

Fig 08



Step 6 Turn the stand over, locate the tool bracket (2) and M6 fixing 6-7-8. Insert the coach bolt (6) through the centre hole in the tool bracket (2) and into the pre-drilled hole in the centre panel (F), angle the bracket and secure using fixing (7-8), (See figs 9-10-11)

Fig 09-10-11



Step 7 Turn the frame over, locate the mitre fence bracket holder and two Phillips screws/washers (1). Lineup the holes in the bracket with threaded holes in the centre panel

Fig 12

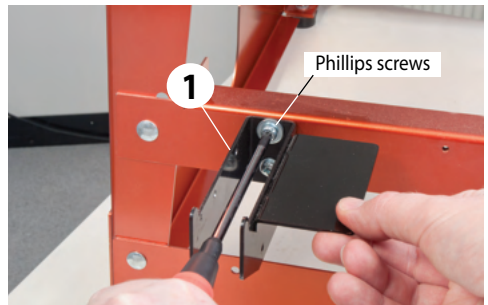

(F) and secure in place with the Phillips screw. (See fig 12).

Step 8 Locate the two (M4) Phillips screws and nuts (5-9), place a nut onto the Phillips screws and screw them into the two threaded hole in the centre panel (F), (See fig 13).

ASSEMBLY

The Phillips screws are for hanging tools for storage. **Note:** Adjust the screw depth and clamp in position using the nut for larger tools.

Fig 13

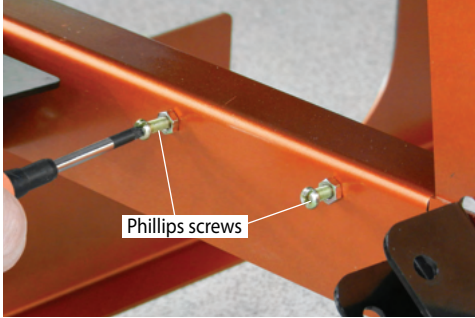

UJK Router Table Top Assembly



WARNING! THE CAST IRON TOP IS VERY HEAVY SEEK HELP!

There are two router table tops that can be mounted to the stand, the Cast Iron and Laminated tables.

NOTE: The Laminated table is secured in place with ten Hex screw while the Cast Iron table only needs four, see fig 15-16.

Step 1 Unpack the table, and it fixings. Lift the table (B) on top of the stand assembly, see fig 14.

Fig 14



Laminated

Fig 15-16



Cast Iron

Locate the Hex screws, flat washers and spring washer and place a spring and flat washer over the Hex threads. Lineup the threaded holes in the table with the holes in the stand and secure in place with the Hex screws, see figs 15-16.

Step 2 Locate the ten countersink Phillips screws and M6 locking nuts, place a nut onto each of the Phillips screws and screw the countersink screws into the ten threaded holes beneath the table insert recess, see figs 17-18.

Fig 17-18



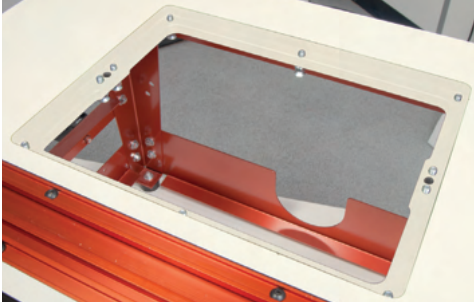

Stand and Table Assembled



Optional Table Inserts

NOTE: There are four options to choose from:

- (Code 105932) **10mm Aluminium Table Insert**
- (Code 502747) **10mm Phenolic Insert**
- (Code 502748) **10mm Aluminium Insert with Universal Base**
- (Code 502701) **UJK Router Elevator**

The following instructions are for the optional UJK 6mm Aluminium table insert but it will apply for the other options as well.

Step 1 Locate the table insert, four grub screws and the two countersink Hex screws. Place the UJK table insert into the tables recess, adjust the ten countersink Phillips screws beneath the table, see fig 23 until the table insert is roughly level with the table surface. Adjust the locking nuts to lock the countersink screws in position, see figs 24-25.

Fig 23

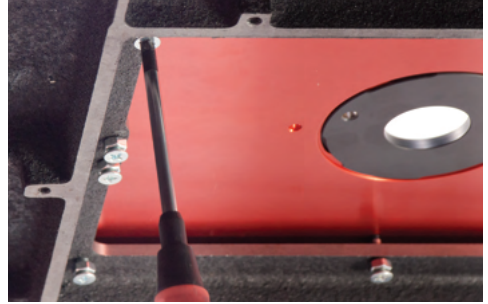
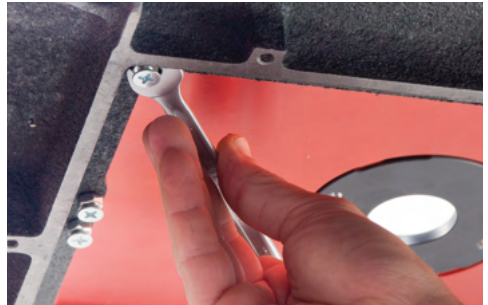
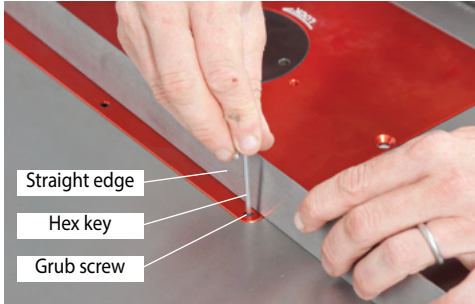

Fig 24-25



Step 2 Insert a grub screw into each threaded corner of the table insert, place a straight edge across the table insert and using a Hex key adjust the grub screws until the table insert is level with the table top, see fig 26.

Fig 26



Step 3 Insert the two countersink Hex screws down into the countersink holes in the table inset to lock the insert in position, see fig 27.

Fig 27

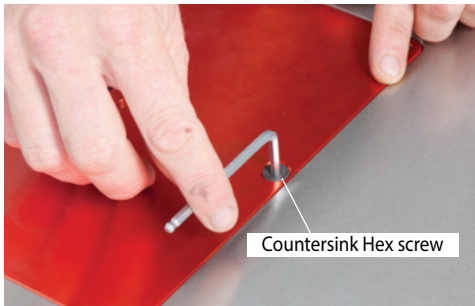

UJK Fence Assembly

Step 1 Locate the fence fixing brackets (L) and the six Hex screws flat and spring washers (f). Line up one of the brackets with the pre-drilled holes beneath the edge of the table and secure in place with four Hex screws (f), see figs 28-29. Repeat for opposite side.

Fig 28-29

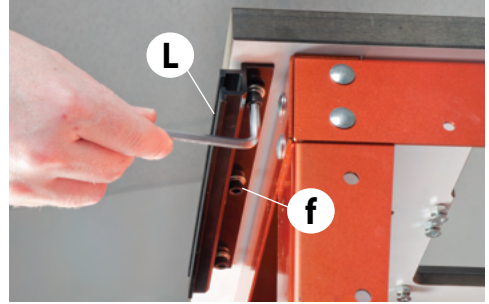

Step 2 Insert three (1/4") square nuts (h) into the machined slot to each fixing bracket (L), see fig 30. Locate the two fence fixing brackets (K), M6 Hex screws (e) and flat washers (j), line up the machined slots in the bracket (K) with the square nuts (h) and secure both brackets with the M6 Hex screws (e), see fig 31. **DO NOT OVERTIGHTEN**

Fig 30-31

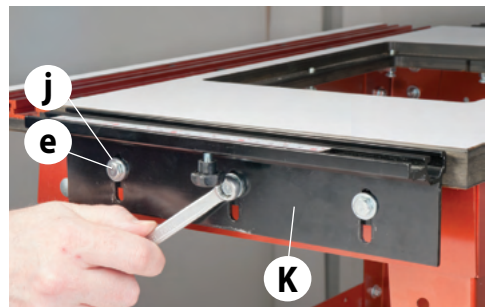
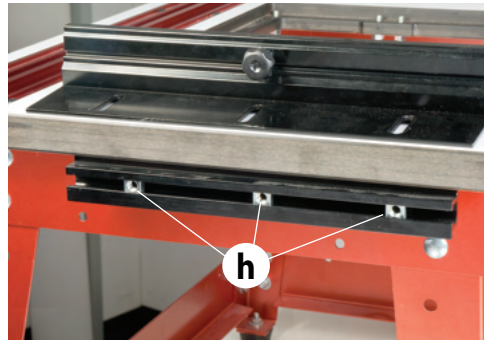

Step 3 Loosen the two locking knobs beneath the fixing brackets (K), slide the two scales into the top of fixing brackets recess and lightly tighten the knobs, see fig 32.

Fig 32

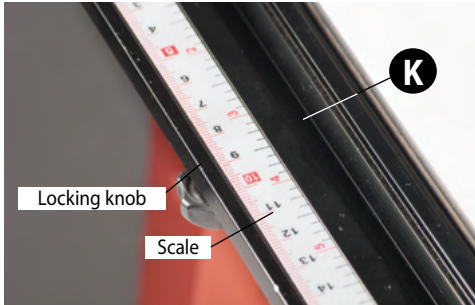

Step 4 Locate the two lock Hex nuts (g) and slide each one into the machined recess in the fixing brackets (K), see fig 33.

Fig 33

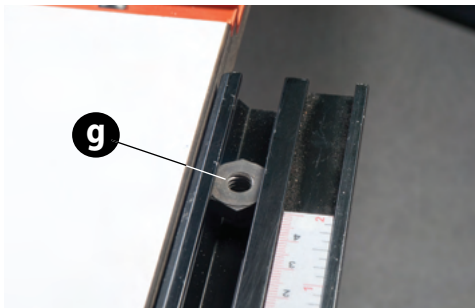

Step 5 Locate the fence assembly (H), 'T' bolts (d) and flat washers (i). Insert six 'T' bolts into the pre-drilled holes in the fence (H), place a washer (i) on each 'T' bolt and screw on the locking knobs (b), see figs 34-35.

Fig 34-35

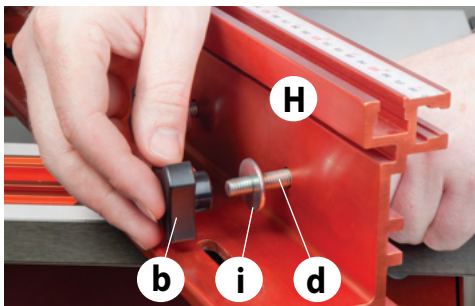

Step 6 Locate the two adjustable wood faces (M), line up the 'T' bolts (d) with the 'T' slots in the wood face (M) and slide on the wood face, lightly tighten, see fig 36. Repeat for the other side.

Fig 36

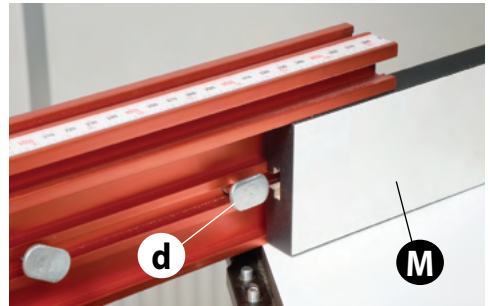

Step 7 Locate the two locking handle knobs (a) and flat washers (i). Line up the machined slots in the fence (H) with the two locking Hex nuts (g) in the fixing bracket (K). Place a washer (i) over the thread on the locking handle knobs (a), screw the handle knobs through the fence base clamping the fence assembly to the table top, see fig 37.

Fig 37

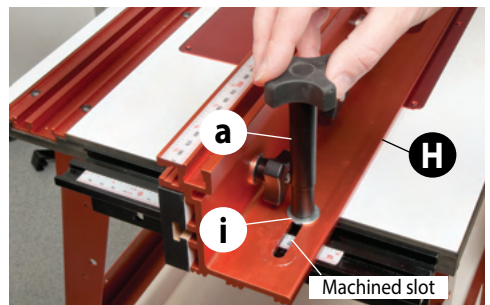

ASSEMBLY

Step 8 Loosen the two locking knobs beneath the fixing brackets (K), slide the two scales until it reads **(ZERO)** to the front face of the fence assembly, lightly tighten the locking knobs, see figs 38-39-40.

Fig 38-39-40

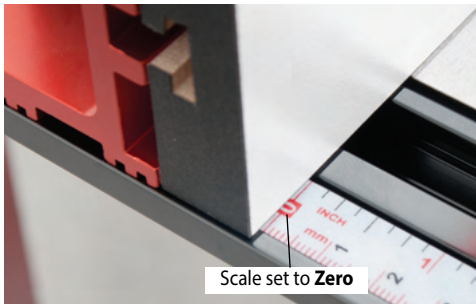
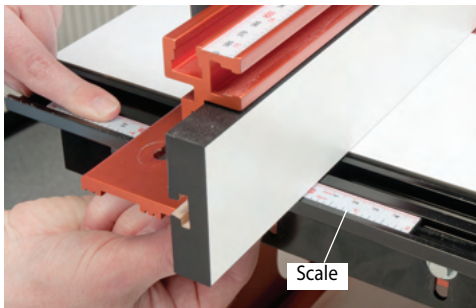
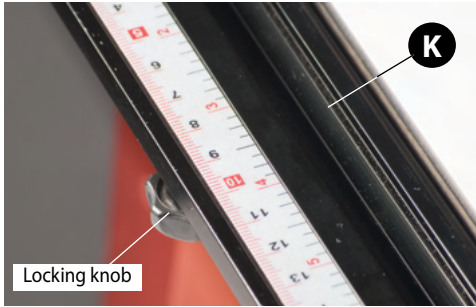

Step 9 Locate the extraction moulding (I), loosen the two locking knobs (b) either side of the extraction surround on the fence (H), slide the extraction moulding (I) over the 'T' bolts (d) and retighten the locking knobs (b), see fig 41



WARNING! DO NOT OVERTIGHTEN THE LOCKING KNOBS AS THE EXTRACTION MOULDING IS ONLY PLASTIC!

Fig 41-42-43



Step 10 Locate two 'T' bolts (d), fence spacers (c) and flat washers (i). Slide the 'T' bolts into the fence (H) 'T' slot and position the bolts roughly the width of the extraction moulding (I) and place a fence spacer (c) over the 'T' bolt thread, see figs 42-43.

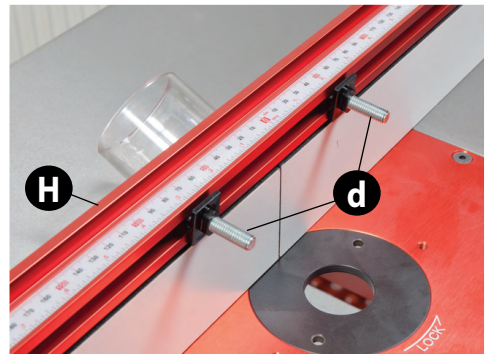

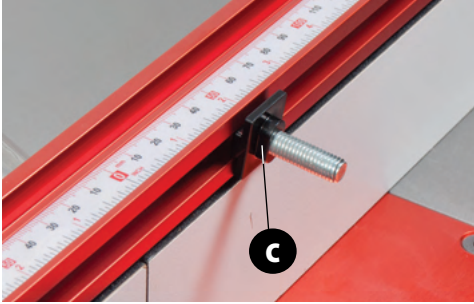

Step 11 Mount the dust shield (J) through the 'T' bolts (d), place a flat washer (i) over the bolts and secure using two locking knobs (b), see figs 44-45.

Fig 44-45

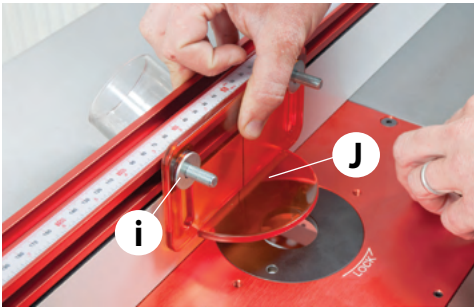

Mitre Fence Assembly

Step 1 Locate the mitre fence(10) and extension (11), Note: the bag of fixings will be tucked inside the extension assembly. Slide the two Hex bolts into the extension 'T' slot. Insert the Hex bolt down into the machined slots in the mitre fence and secure the assembly with the two wing nuts, see fig 46. **DO NOT OVERTIGHTEN!**

Fig 46-47

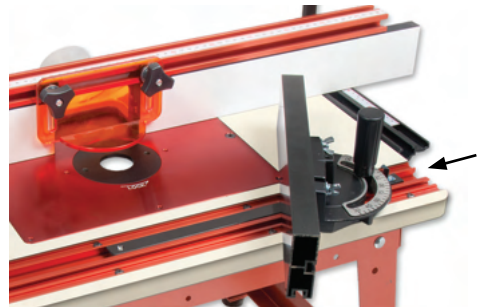
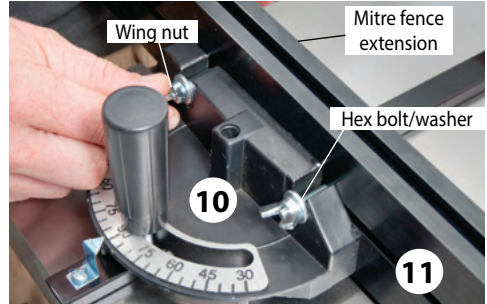

Tool Storage Holders

To store your tools when not in use, place the mitre fence assembly into the mitre fence bracket (1), hook the insert plate spanner over one of the two Phillips screw hangers and Insert the shaft of the winding handle from UJK router elevator, (code 502701) through the pre-drilled hole in the tool bracket (2), see fig 48.

Fig 48

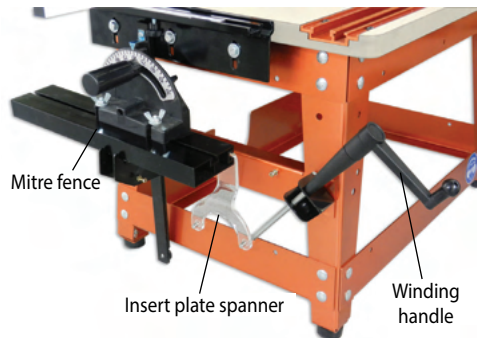

ILLUSTRATION & PARTS DESCRIPTION

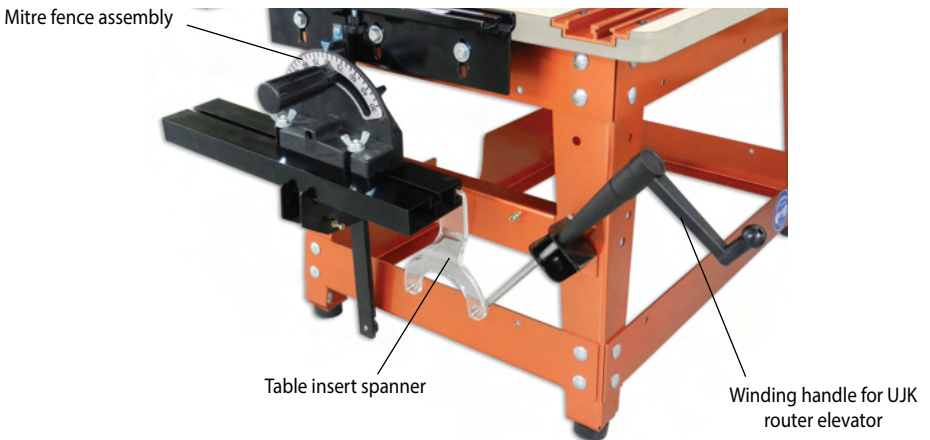
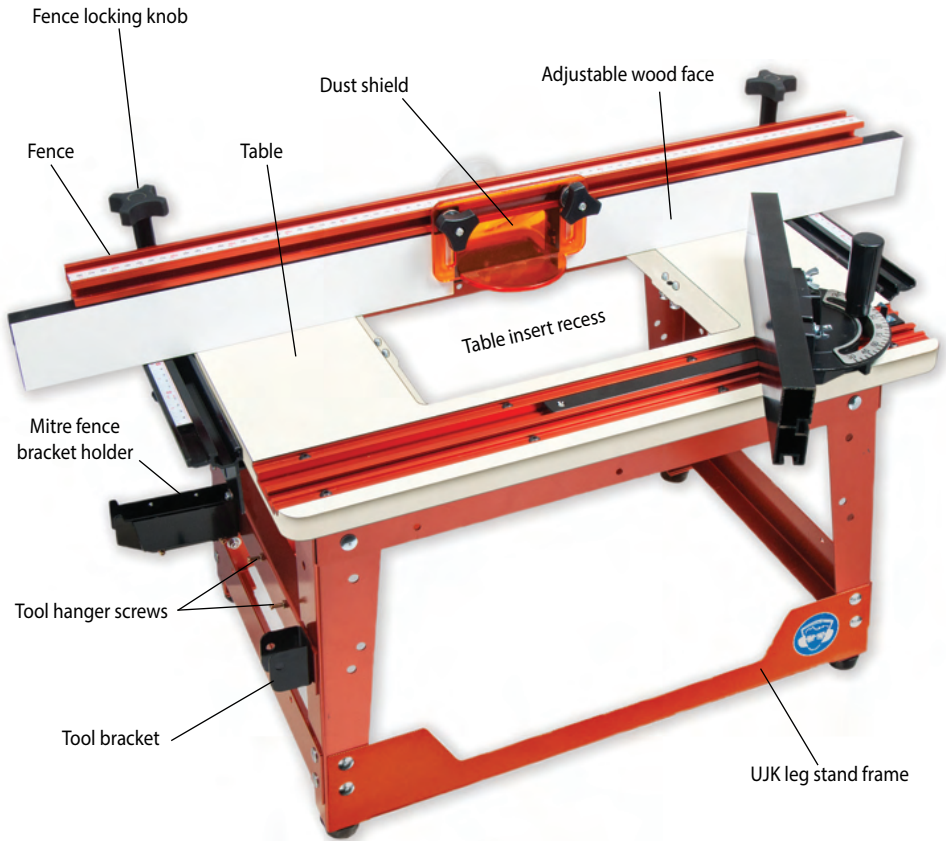
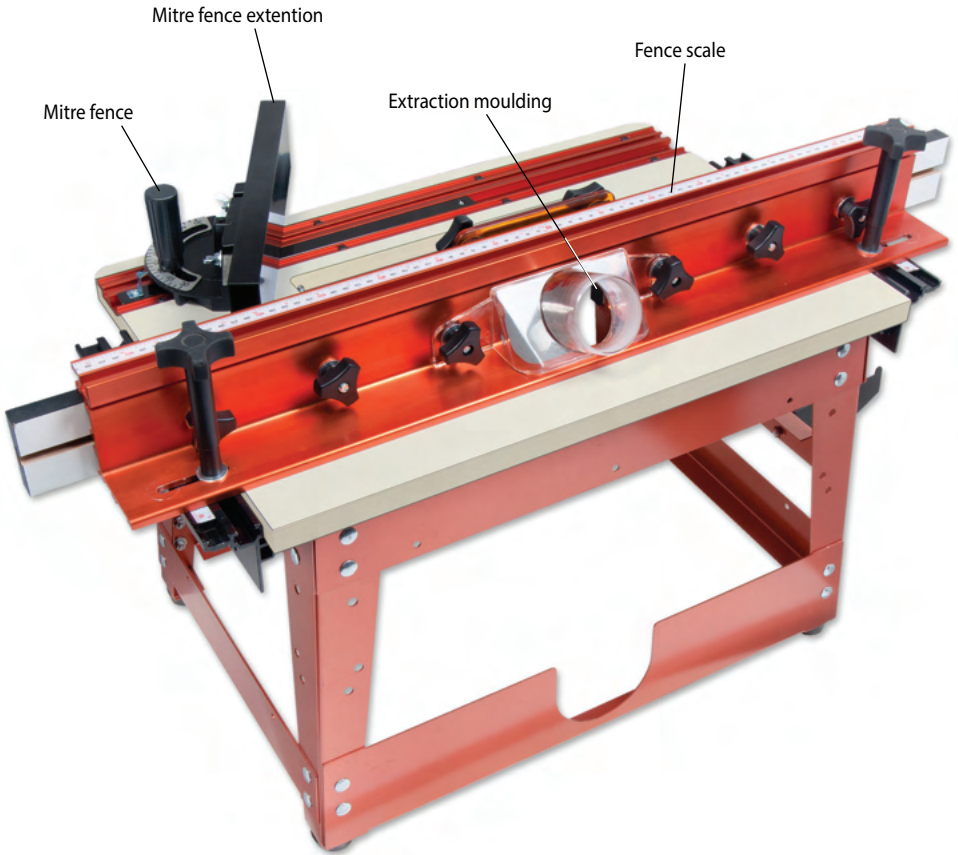

ILLUSTRATION & PARTS DESCRIPTION



UJK router table with optional dust extraction box attached

MOUNTING THE ROUTER TO THE UNIVERSAL BASE PLATE



10mm Aluminium Router Table Insert with Universal Base Plate

(Code 502748)

The information below is reproduced from the UJK universal base plate fitting instructions. Hole numbers, screw types and how many required are given for mounting different router models to the base plate.

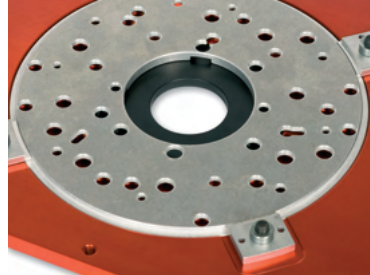
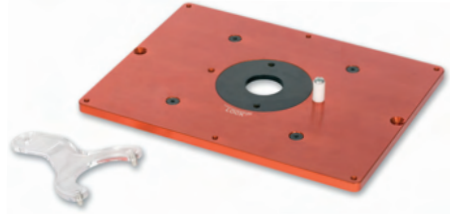





For advice on models suitable for fitting to the router elevator please call our technical sales team on 03332 406406



	New switch regulations means NVR Switch cannot be used!
	Handles may need to be removed!

ROUTER CHART



BOSCH	GOF1600,1700ACE POF52,	1	Fx2	HITACHI	M8(V) 	10	Dx4	
	400,500A,600ACE	3	Fx2		M12V,M12SA	11	Dx4	
	POF800ACE.GOF900A <2003	4	Gx3		TR12	11-12	Dx4	
	GOF1300ACE,900A>2003	5	Gx3		HIKOKI	M12VE		
	GMF1400	0	lx4			MAFELL	L050E	8
CMT	CMT1E,CMT2E	1	Fx2	MAKITA	3620,3612BR,3600B		13	Dx2
	DEWALT	DW613,614,615,620,621, DW625EK.629, DW625EK  	1		Fx2	3612(C)  	14	Ex2
DRAPER		R1900V	2	Fx3	RP0910, RP1110C, RP1111C  	1	Fx2	
		PT1200V	1	Fx3	RP2301FC, RP230FC	22	Bx4	
ELU	OF97(E),MOF177(E),131,98, MOF77,96(E) MK2,69'	1	Fx2	PRO	CLM1250R>11/03,CLM2050R	1	Fx2	
	FELISATTI	R346EC	1		Ex2	PERLES	OF808(E)>1999',2-808(E), OF9(E)	1
FESTOOL		OF2000(E)	7	Ex3	PEUGEOT	DEF570E.DF55E	15	Ex2
	OF1E,900(E),1000(E), OF1010	8	Bx4 & Ax3	RYOBI		RE600N,R600N,RE601, ERT1500V	13	Dx2
FREUD	OF1400 EBQ-Plus	23	Hx2		R500,502	16	Ax4	
	FT1000(E),2000E	2	Fx3	R150,151,RE120,155K	15	Ex2		
				SKIL	1835U.1875U1	17	Cx3	
					TREND	T3,T4,T5,T5MK2', T9,T10,T11, T7EK	10	Ax2
				TRITON		MOF001, TRA001	21 2 5	1/4" UNC 6.35mm
					WADKIN	R500	16	Ax4

MOUNTING THE ROUTER TO THE UNIVERSAL BASE PLATE

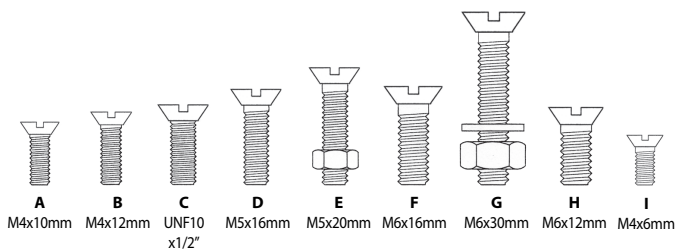
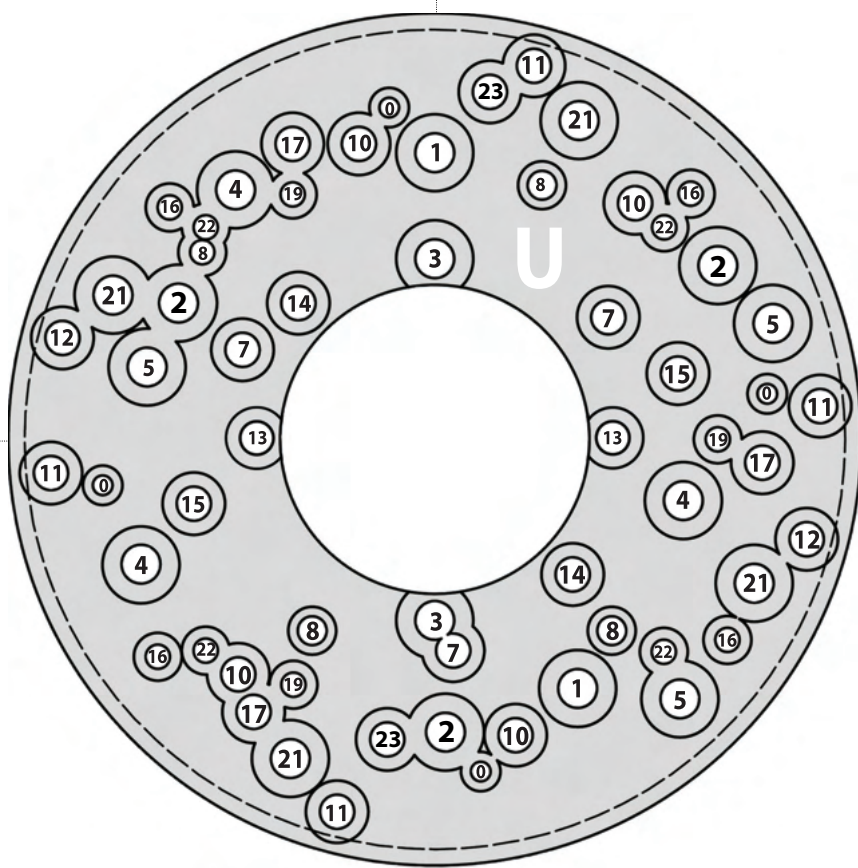

MOUNTING THE ROUTER TO THE 10MM TABLE INSERTS

Fig 01



• **10mm Aluminium Table Insert**
(Code 105932)



• **10mm Phenolic Insert**
(Code 502747)

What's Included

1 No	Insert Plate	A
1 No	Insert Plate Template	B
2 No	Table Fixing Screws	C
1 No	Table inset Spanner	
1 No	4mm, 3mm Hex Keys	
6 No	Grub Screws	
1 No	Template Pin	

Marking & Positioning

NOTE: You will notice the 6mm Aluminium or 10mm Phenolic insert plates will not have any mounting holes for a router. This is because there are so many routers on the market, each having different hole locations.

NOTE: Remember to orientate the router so that the handles will clear the recess and the height adjustment is in easy reach.

Step 1 Turn over your router, place a small diameter cutter into the collet, see fig 1, this is to act as a guide for lining up the template (B).

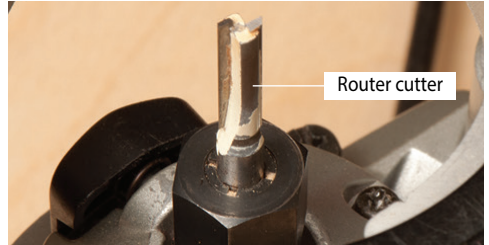

Step 2 Place the template (B) on top of the router, line up the concentric circle ridges with the router base plate and the centre of the template with the centre of the cutter, see fig 02.

Fig 02

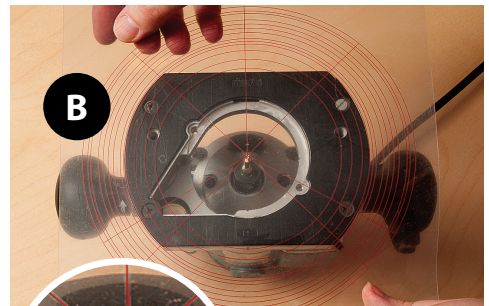

The template centred over the router cutter

Step 3 Using a marker pen, mark the position of the threaded holes on the base of the router, see fig 3

MOUNTING THE ROUTER TO THE 10MM TABLE INSERTS

Fig 05-06



NOTE: THIS MAY VARY DEPENDING ON ROUTER MODEL

Fig 03

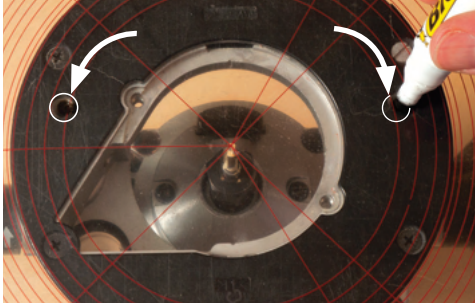

Step 4 Turn over the insert plate (A) (with the logo face down), place the template (B) on top of the insert plate and centre the template as shown, see fig 4

Fig 04

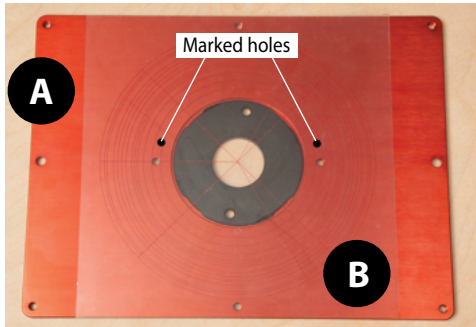

Step 5 Secure the template (B) in position using Sellotape, see fig 05. Using a centre punch mark the position of the holes on the insert plate (A), see fig 06. Remove the template and place safely aside.



NOTE: IT IS GOOD PRACTISE TO CENTRE PUNCH THE POSITION BEFORE DRILLING AS THIS WILL GUIDE THE DRILL!

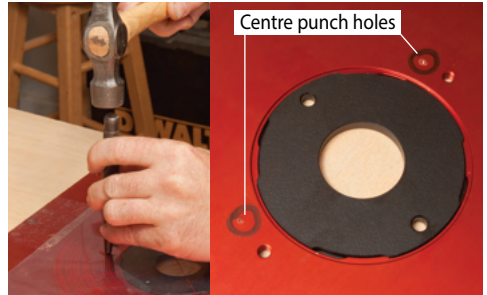
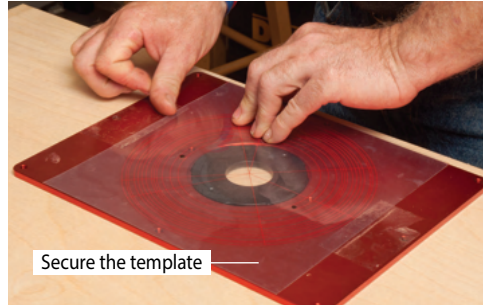

NOTE: TO MAKE SURE THE HOLES ARE ACCURATE WE RECOMMEND YOU USE A DRILL PRESS!



WARNING! MAKE SURE THE INSERT PLATE IS SECURELY CLAMPED DOWN TO THE DRILL TABLE!



REMEMBER THAT THE COUNTER-SINK MUST BE DEEP ENOUGH FOR THE SCREW HEAD TO BE FLUSH OR SLIGHTLY SUB-SURFACE, SO THAT THE TIMBER IS NOT IMPEDED WHEN IT IS MOVED OVER THE SURFACE.

MOUNTING THE ROUTER TO THE 10MM TABLE INSERTS

Fig 07-08

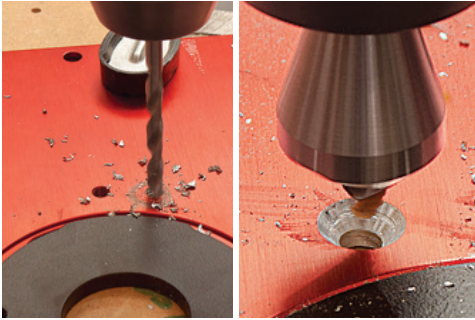

Step 7 Fix the insert plate (A) to the router (screws not provided). Lightly tighten each fixing screw, evenly working down each screw till secure, see figs 09-10.



Fig 09

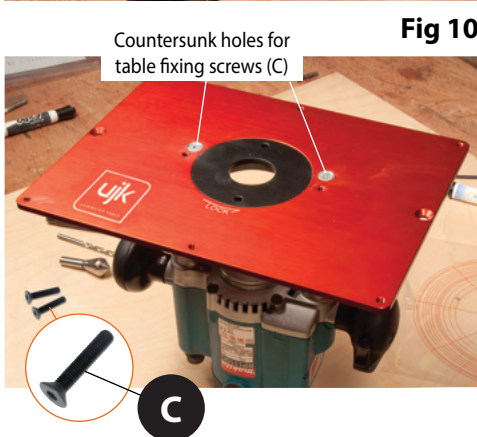

Fig 10

Connecting a Dust Extractor



BEFORE ROUTING CONNECT THE MACHINE TO A DUST EXTRACTION SYSTEM. ALWAYS TURN ON THE DUST EXTRACTOR BEFORE STARTING THE ROUTER AND ALWAYS STOP THE ROUTER BEFORE TURNING OFF THE DUST EXTRACTOR.

There is a 62mm dust outlet on the rear of the fence assembly allowing for the connection of a dust extractor (**not included**).

Be sure to use an appropriate size hose and fittings and check that all connections are sealed tightly to minimize airborne dust.



MAKE SURE TO READ, AND FOLLOW ALL OPERATING INSTRUCTIONS AND SAFETY GUIDELINES THAT CAME WITH YOUR ROUTER FAILURE TO DO SO MAY LEAD TO SERIOUS INJURY AND/OR DAMAGE TO THE ROUTER, ROUTER TABLE, OR WORKPIECE.

- Install the required bit in your router according to the instructions supplied with your router.

- Make sure that the router is firmly attached to the table insert and that the plate is properly fitted and level in the table opening (see pages 16-17), fitting table insert.

- The router table should be installed on a flat, sturdy, and stable surface.

- When jointing, groove cutting, and/or profile cutting always perform a test cut on a scrap piece of wood before cutting your final piece.

History

The cutters that are used with a router have developed over the last 35 years to allow a variety of tasks to be obtainable with the use of a hand held power tool. These developments have improved the work finish and more importantly, the safety of the operator.

(HSS) High Speed Cutters

High speed steel cutters (HSS) are ground out of a solid piece of high speed steel. These are cheaper to produce than TCT cutters, which is reflected in the price of the item. These can be ground to a fine edge as the material is not as hard as TCT but it does not hold the cutting edge as well. Due to the angle of the rake, they are more prone to kick back or snatching. They are suitable for use with non abrasive natural timbers and PVC.

(TCT) Tungsten Carbide Tipped Cutters

TCT (Tungsten Carbide Tipped) cutters have the main body and shank machined from high grade steel but have tungsten carbide tips brazed into each flute. This set up gives a number of benefits. The reduced rake angle helps to reduce kickback and snatching. The TCT cannot be honed to such a sharp edge as HSS but will last a lot longer than HSS cutters. The better quality cutters have a thicker section of carbide. The best carbide cutters are produced with micro granular grades of tungsten. The outer edge of the blade will be polished and shiny (diamond sharpened) not dull and serrated. Tungsten Carbide is extremely brittle and prone to chipping if knocked or dropped; this is why it is important to store your cutters carefully. Tungsten Carbide is suitable for all round use including; natural timbers, manufactured boards, plywood, chipboard, MDF, glass reinforced plastics, acrylics and hard plastic like Corian.

(STC) Solid Tungsten Carbide Cutters

STC (Solid Tungsten Carbide) cutters are ground from a solid section of tungsten carbide. These provide the best durability when used under stress load operation. Smaller diameter cutters are ground from this as it is impossible to insert a TCT in smaller sections. Solid Tungsten Carbide is also better for operations where deep plunge cuts are required, e.g. cutting mortise slots. These cutters have a spiral section ground into the cutter face to remove the waste material.

Arbour Mounted Cutters

Arbour mounted cutters have a parallel shank (1/4" or 1/2") and a machine thread at the bottom. Interchangeable cutters called "slot cutters" can be fixed onto these. The use of shims, spacers, washers and a locking nut fix hold the slot cutters on the cutter. It is possible to mount more than one disc on these at a time. Care needs to be taken when mounting the slot cutters as it is very easy to mount these upside down. A good reference is viewing the standard router cutter.

Pin & Bearing Guided Cutters

Within this range of cutters, there are a few that will be classed as self guiding. These are;

- Pin Guided - these have a machined pin on the bottom of the cutter body. They are cheaper to produce and need extra care as it is possible to friction burn the work piece using these.
- Bearing Guided - these have a ball bearing guide that can be top or bottom mounted. The bearing is designed to follow a template or run on the work piece itself. Different sized bearings can also be fitted on some cutters to increase or decrease the maximum depth of cut. Less friction is created so the work piece will not be burnt. The bearings will wear out but can easily be replaced.

GENERAL GUIDE TO ROUTER CUTTERS

Shanks and Cutter Length

1/2" shank cutters are inherently stronger which means they are less likely to bend or snap than the small 1/4" shank. Certain cutters can only be purchased on 1/2" shank (door set and worktop cutters). This strength allows for cutters of a larger diameter and longer length as appose to the 1/4" shank.

It is very important with both 1/4" and 1/2" shanks to feed the cut using a mixture of plunge depth and cutter shank. This will reduce the damage to cutters and the wear on the router bearings. Try to take more than one pass, this will allow for a better finish and reduce damage to the router and the cutters (1/4" is more likely to bend with a heavy cut). As a general guide a 1/4" (6.35mm) cutter should take less than half of this measurement as its cut i.e. 3mm.

This rule is very difficult to enforce as some cuts will combine, using the total diameter and a side cut. So what do we class as 3mm? The major factor being the material density which will affect how much material can safely be removed.

Modern cutters have to have a safe hold (K) line and a maximum running speed engraved upon the shank as a general guide. 2/3 of the cutter shank should be held in the collet. As for speed, the noise of the router will give you a guide.

The speed of the cutter will vary with materials but it is important to vary the speed feed of the operator moving the router over the work piece or the speed in which they pass the work through the cutter set up on a table. Give the cutter time to remove the stock to achieve a clean finish.



1/4" Router Cutter



1/2" Router Cutter

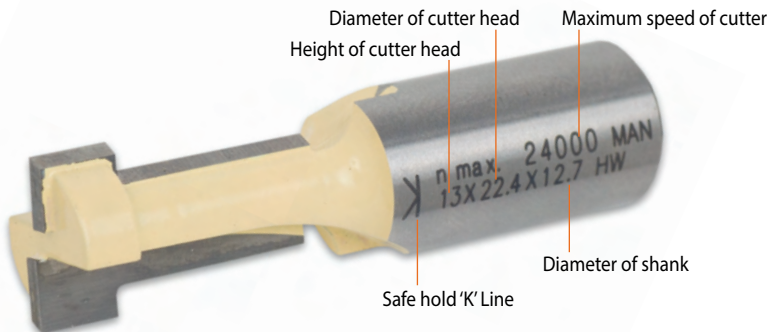

Router Table & Stand Assembly(E Type)

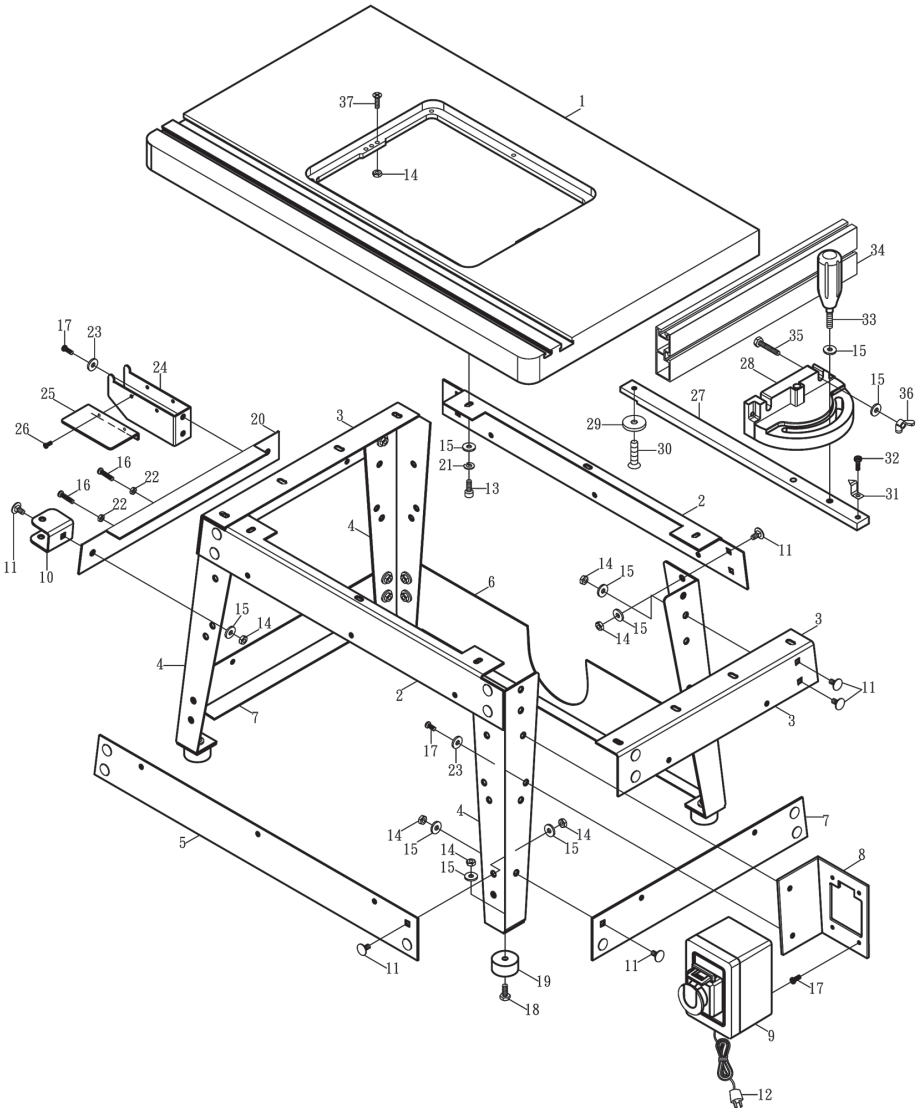

EXPLODED DIAGRAM/PARTS LIST

Router Table & Stand Assembly (E Type)				
Index No	Part No	Description	Size	Qty
1	2716E014	Router Table	(686mm×407mm)	1
2	27160015	Stand Cross Relief		2
3	27160016	Stand Side Support		2
4	27160017	Stand Leg		4
5	27160018	Stand Tie Bar (Front		1
6	27160018A	Stand Tie Bar (Rear		1
7	27160019	Stand Tie Bar (L&R		2
8	27160022	Switch Base (OPTIONAL)		1
9	S3224002	Switch Box (OPTIONAL)		1
10	27160020	Handle Bracket		1
11	909M06012	Carriage Bolt	M6×12	34
12	L3224001	Power Cord (OPTIONAL)	1.5 mm ² ×3C	1
14	910M06000	Hex Nut	M6	48
15	914M061602	Flat Washer	M6	41
16	906M04020	Round Head Screw	M4×20	2
17	906M05008	Round Head Screw	M5×08	8
18	904M06020	Hex Cap Bolt	M6×20	4
19	30100016	Rubber Foot		4
20	27160021	Tool Storage		1
22	910M05000	Hex Nut	M4	2
23	914M051201	Flat Washer	M5	4
24	10400109	Fence Hook		1
25	32240056	Hook Extension Plate		1
26	906M04005	Round Head Screw	M4×5	2
27	22100118	Guide Bar		1
28	22100119	Miter Gauge Body		1
29	10100206	Guide Washer		1
30	905M06008	Flat Head Screw	M6×8	1

EXPLODED DIAGRAM/PARTS LIST

31	22100120	Pointer		1
32	906316014	Round Head Screw	3/16"×1/4"	1
33	938014025	Lock Knob	1/4"×25	1
34	32240057	Miter Fence		1
35	904M06030	Hex Cap Bolt	M6×30	2
36	913M06000	Butterfly Nut	M6	2
37	905M06020	Flat Head Screw	M6×20	10

Router Table Fence Assembly

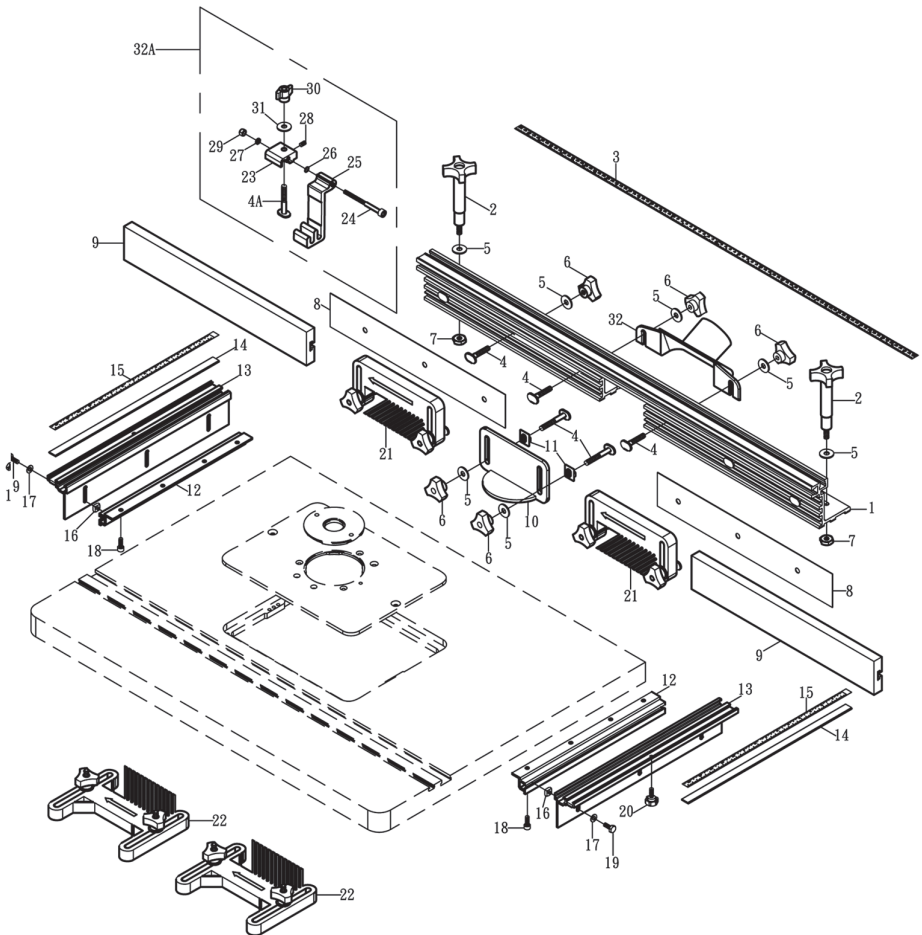

EXPLODED DIAGRAM/PARTS LIST

Router Table Fence Assembly

Index No	Part No	Description	Size	Qty
1	32240032	Router Table Fence	905mm	1
	27160032	Router Table Fence	778mm	1
2	60100001A	Lock Handle	5/16"	2
3	T3224002	Scale	905mm	1
	T2716002	Scale	778mm	1
4	32240033	T-Bolt		8
5	9145162302	Flat Washer	M8	10
6	939M08000B	Lock Knob	M8	8
7	32240034	Lock Nut	M8	2
8	32240035	Shim For Sub Fence (Optional)	401mm	2
	32240035	Shim For Sub Fence (Optional)	338mm	2
9	32240036	Router Table Fence Faces	451mm	2
	27160036	Router Table Fence Faces	388mm	2
10	32240037	Safety Guard		1
11	32240038	Fence Spacer		2
12	32240039	Side Bracket Base	320mm	2
	27160039	Side Bracket Base	240mm	2
13	32240040	Side Bracket	375mm	2
	27160040	Side Bracket	280mm	2
14	32240041	Rule Plate	300mm	2

EXPLODED DIAGRAM/PARTS LIST

	27160041	Rule Plate	205mm	2
15	T3224003	Scale	300mm	2
	T2716003	Scale	205mm	2
16	935014000	Square Nut	1/4"	6
17	9140141602	Flat Washer	M6	6
18	901M06012	Hex Socket Cap Screw 3224	M6x12	8
	901M06012	Hex Socket Cap Screw 2716	M6x12	6
19	904014058	Hex Bolt	1/4"x5/8"	6
20	940M06012	Lock Knob	M6x12	2
21	32240042	Fence Feather board	(Optional)	2
22	32240043	Table Feather board	(Optional)	2
23	32240044	Clamping Bracket	(Optional)	1
24	32240045	Hex Socket Cap Screw (Optional)	M6x75	1
25	32240046	Clamping	(Optional)	1
26	32240047	Flat Washer	(Optional)	1
27	32240048	Flat Washer	(Optional)	1
28	908M06016	Set Screw	(Optional) M6x16	1
29	912M06000	Nylon Nut	(Optional) M6	1
30	939M08000C	Lock Knob	(Optional) M8	1
31	9145161802	Flat Washer	(Optional) M8	1
32	32240013	Dust Port		1
32A	32240043A	Flip Stop Assembly	(Optional)	1



Only for EU countries



Do not dispose of electric tools together with household waste material. In observance of European Directive 2002/96/EC on waste electrical and electronic equipment and its implementation in accordance with national law, electric tools that have reached the end of their life must be collected separately and returned to an environmentally compatible recycling facility.



Please dispose of packaging for the product in a responsible manner. It is suitable for recycling. Help to protect the environment, take the packaging to the local recycling centre and place into the appropriate recycling bin.



UJK, Weycroft Avenue, Axminster, Devon EX13 5PH

ujktools.com